



NW



Assemblati Con Dado e Rondella > Assembled With Nut and Washer > Assemblés Avec Écrou et Rondelle > Zusammengesetzte Anker mit Mutter und Scheibe

> **Materiale** > **Material** > **Matériel** > **Material**



5 µm
micron

NWS-CE1 / NWS-CE / NW-S / NW-CE / NW-B
TASSELLO/DADO/RONDELLA: Acciaio zincato bianco
ANCHORS/NUT/WASHER: White zinc plated steel
CHEVILLES/ECROU/RONDELLE: Acier zingué blanc
DÜBEL/MUTTER/SCHEIBE: Blau/Weiß Verzinkter Stahl



NWS-CE-X4
Inox A4 AISI 316



NWS-CE1
FASCETTA: Inox A4 AISI 316
EXPANSION CLIP: Inox A4 AISI 316
COLLIER D'EXPANSION: Inox A4 AISI 316
SCHELLE: Inox A4 AISI 316



5 µm
micron

NW-S / NWS-CE
FASCETTA: Acciaio zincato bianco
EXPANSION CLIP: White zinc plated steel
COLLIER D'EXPANSION: Acier zingué blanc
SCHELLE: Blau/Weiß Verzinkter Stahl



NW-X2
TASSELLO/DADO/CONO/RONDELLA/FASCETTA: Inox A2 AISI 304
ANCHOR/NUT/CONE/WASHER/ EXPANSION CLIP: Inox A2 AISI 304
CHEVILLE/ECROU/CONE/RONDELLE/COLLIER D'EXPANSION: Inox A2 AISI 304
DÜBEL/MUTTER/KEGEL/SCHEIBE/SCHELLE: Inox A2 AISI 304

> **Omologazioni** > **Approval** > **Homologation** > **Zulassung**



> **Applicazioni** > **Applications** > **Applications** > **Anwendungen**



Edilizia Civile
Pesante
Heavy Building
Construction
Construction Civile
Lourde
Schweres
Zivilbauwesen



Edilizia Industriale
Pesante
Heavy Industrial
Construction
Construction Industriel
Lourde
Schweres
Industriellbauwesen



Settore Elettrico
Pesante
Heavy Electricity
Area
Secteur Electrique
Lourd
Schweres
Elektrischenwesen



Settore Idraulico
e Lattoneria pesante
Heavy Hydraulic and
Tiling Area
Secteur lourde
Hydraulique
et Ferblanterie
Starke Hydraulikwesen
und Blecharbeiten

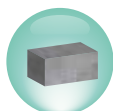

Calcestruzzo
Concrete
Beton
Beton



Pietra
Stone
Pierre
Stein



Presenza d'acqua
Water in place
Eau sur place
Wasser in Platz



Ambiente Urbano Medio
Inquinamento
Middle Urban Pollution
Moyenne Pollution
en Ville
Mittlere
Stadtverschmutzung



Fuoco
Fire
Feu
Feuer



Ambiente Urbano
Alto Inquinamento
Heavy Urban Pollution
Grande Pollution en Ville
Starke
Stadtverschmutzung

NWS-CE1

NW-X2

PROCEDURA DI INSTALLAZIONE
INSTALLATION PROCEDURE
PROCÉDURE D'INSTALLATION
INSTALLATIONSVERFAHREN

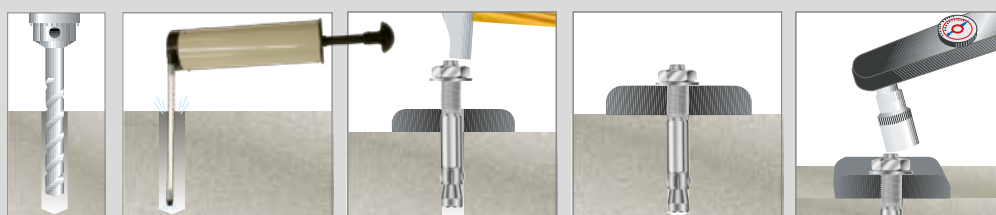



SCHEDA TECNICA TECHNICAL DATA SHEET FICHE TECHNIQUE TECHNISCHES DATENBLATT

> Dati tecnici > Technical data > Données techniques > Technische Angaben

LEGENDA	Descrizione
d [mm]	Diametro filettatura > Thread diameter > Diamètre du filetage > Gewindedurchmesser
d _{nom} [mm]	Diametro esterno ancorante > Outside diameter of anchor Diamètre externe d'ancrage > Außendurchmesser des dübels
L [mm]	Lunghezza totale ancorante > Total length of anchor Longueur élément d'ancrage > Dübellänge
dxL [mm x mm]	Filettatura diametro x lunghezza > Thread diameter x length Diamètre du filetage x longueur > Gewinde x Dübellänge
t _{fix} [mm]	Spessore fissabile (max) > Fixture thickness (max) Épaisseur fixable (max) > Max. Anbauteildicke

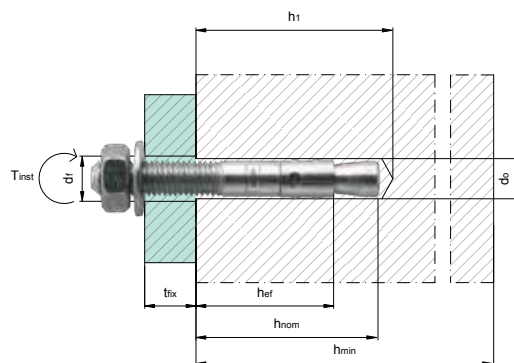

NWS-CE1



Con Dado e Rondella > With Nut and Washer
Avec Écrou et Rondelle > Mit Mutter und Scheibe



Option 1

CODICE CODE	ARTICOLO ITEM	DIAMETRO FILETTATURA THREAD DIAMETER	DIAMETRO ESTERNO ANCORANTE OUTSIDE DIAMETER OF ANCHOR	LUNGHEZZA TOTALE ANCORANTE TOTAL LENGTH OF ANCHOR	FILETTATURA DIAMETRO X LUNGHEZZA THREAD DIAMETER X LENGTH	SPESSORE FISSABILE (MAX) FIXTURE THICKNESS (MAX)	Nr.
	NW-S	d [mm]	d _{nom} [mm]	L [mm]	dxL [mm x mm]	t _{fix} [mm]	
708971	NWS-CE1 8-75	M8	8	75	M8 x 43	9	100
708972	NWS-CE1 8-95	M8	8	95	M8 x 63	29	100
708973	NWS-CE1 8-115	M8	8	115	M8 x 83	49	100
708975	NWS-CE1 10-90	M10	10	90	M10 x 53	10	100
708976	NWS-CE1 10-105	M10	10	105	M10 x 58	25	50
708977	NWS-CE1 10-115	M10	10	115	M10 x 78	35	50
708978	NWS-CE1 10-135	M10	10	135	M10 x 98	55	50
708979	NWS-CE1 10-165	M10	10	165	M10 x 128	85	50
708980	NWS-CE1 10-185	M10	10	185	M10 x 148	105	50
708984	NWS-CE1 12-110	M12	12	110	M12 x 66	14	50
708985	NWS-CE1 12-120	M12	12	120	M12 x 76	24	50
708986	NWS-CE1 12-130	M12	12	130	M12 x 86	34	50
708987	NWS-CE1 12-150	M12	12	150	M12 x 106	54	50
708988	NWS-CE1 12-180	M12	12	180	M12 x 136	84	50
708989	NWS-CE1 12-200	M12	12	200	M12 x 156	104	50
708992	NWS-CE1 16-145	M16	16	145	M16 x 92	28	25
708993	NWS-CE1 16-175	M16	16	175	M16 x 122	58	25
708994	NWS-CE1 16-220	M16	16	220	M16 x 167	103	25
708995	NWS-CE1 16-250	M16	16	250	M16 x 197	133	25
708996	NWS-CE1 20-170	M20	20	170	M20 x 110	32	20
708997	NWS-CE1 20-200	M20	20	200	M20 x 140	62	20



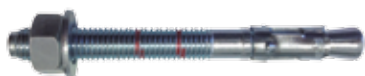

NWS-CE



Con Dado e Rondella > With Nut and Washer
Avec Écrou et Rondelle > Mit Mutter und Scheibe





Option 7

CODICE CODE	ARTICOLO ITEM	DIAMETRO FILETTATURA THREAD DIAMETER	DIAMETRO ESTERNO ANCORANTE OUTSIDE DIAMETER OF ANCHOR	LUNGHEZZA TOTALE ANCORANTE TOTAL LENGTH OF ANCHOR	FILETTATURA DIAMETRO X LUNGHEZZA THREAD DIAMETER X LENGTH	SPESSORE FISSABILE (MAX) FIXTURE THICKNESS (MAX)	
 NWS-CE		d [mm]	d _{nom} [mm]	L [mm]	dxL [mm x mm]	t _{fix} [mm]	Nr.
709200	NWS-CE 6-60	M6	6	60	M6 x 27	2	200
709201	NWS-CE 6-70	M6	6	70	M6 x 37	12	200
709202	NWS-CE 6-80	M6	6	80	M6 x 47	22	200
709203	NWS-CE 6-90	M6	6	90	M6 x 57	32	200
709204	NWS-CE 6-100	M6	6	100	M6 x 67	42	200
709205	NWS-CE 6-110	M6	6	110	M6 x 77	52	200
709206	NWS-CE 6-120	M6	6	120	M6 x 87	62	100
709207	NWS-CE 6-130	M6	6	130	M6 x 97	72	100
709208	NWS-CE 6-140	M6	6	140	M6 x 107	82	100
709209	NWS-CE 8-60 *	M8	8	60	M8 x 25	3	200
709210	NWS-CE 8-75	M8	8	75	M8 x 39	5	100
709211	NWS-CE 8-90	M8	8	90	M8 x 54	20	100
709212	NWS-CE 8-115	M8	8	115	M8 x 79	45	100
709213	NWS-CE 8-130	M8	8	130	M8 x 94	60	100
709214	NWS-CE 10-70 *	M10	10	70	M10 x 29	3	100
709215	NWS-CE 10-80 *	M10	10	80	M10 x 39	13	100
709216	NWS-CE 10-90	M10	10	90	M10 x 49	10	100
709217	NWS-CE 10-100	M10	10	100	M10 x 59	20	100
709218	NWS-CE 10-120	M10	10	120	M10 x 79	40	50
709219	NWS-CE 10-150	M10	10	150	M10 x 109	70	50
709220	NWS-CE 10-170	M10	10	170	M10 x 129	90	50
709221	NWS-CE 10-210	M10	10	210	M10 x 169	130	50
709222	NWS-CE 10-230	M10	10	230	M10 x 189	150	50
709224	NWS-CE 12-90 *	M12	12	90	M12 x 38	13	50
709225	NWS-CE 12-100 *	M12	12	100	M12 x 48	23	50
709226	NWS-CE 12-110	M12	12	110	M12 x 58	18	50
709227	NWS-CE 12-120	M12	12	120	M12 x 68	28	50

(*) Con affondamento ridotto > Reduced embedment depth > Profondeuse d'ancrage reduites > Anwendungen mit reduzierte Verankerungstiefen



SCHEDA TECNICA TECHNICAL DATA SHEET FICHE TECHNIQUE TECHNISCHES DATENBLATT

CODICE CODE	ARTICOLO ITEM	DIAMETRO FILETTATURA THREAD DIAMETER	DIAMETRO ESTERNO ANCORANTE OUTSIDE DIAMETER OF ANCHOR	LUNGHEZZA TOTALE ANCORANTE TOTAL LENGTH OF ANCHOR	FILETTATURA DIAMETRO X LUNGHEZZA THREAD DIAMETER X LENGTH	SPESSORE FISSABILE (MAX) FIXTURE THICKNESS (MAX)	
 	NWS - CE	d [mm]	d _{nom} [mm]	L [mm]	dxL [mm x mm]	t _{fix} [mm]	Nr.
709228	NWS-CE 12-140	M12	12	140	M12 x 88	48	50
709229	NWS-CE 12-160	M12	12	160	M12 x 108	68	50
709230	NWS-CE 12-180	M12	12	180	M12 x 128	88	50
709231	NWS-CE 12-220	M12	12	220	M12 x 168	128	50
709232	NWS-CE 12-250	M12	12	250	M12 x 198	158	25
709233	NWS-CE 14-120	M14	14	120	M14 x 63	12	25
709234	NWS-CE 14-145	M14	14	145	M14 x 88	37	25
709235	NWS-CE 14-170	M14	14	170	M14 x 113	62	25
709236	NWS-CE 14-220	M14	14	220	M14 x 163	112	25
709237	NWS-CE 14-250	M14	14	250	M14 x 193	142	25
709238	NWS-CE 16-125	M16	16	125	M16 x 60	3	25
709239	NWS-CE 16-145	M16	16	145	M16 x 80	23	25
709240	NWS-CE 16-175	M16	16	175	M16 x 110	53	25
709241	NWS-CE 16-220	M16	16	220	M16 x 155	98	25
709242	NWS-CE 16-250	M16	16	250	M16 x 185	128	25
709243	NWS-CE 16-280	M16	16	280	M16 x 215	158	25
709244	NWS-CE 20-170	M20	20	170	M20 x 102	23	20
709245	NWS-CE 20-220	M20	20	220	M20 x 152	73	20
709246	NWS-CE 20-270	M20	20	270	M20 x 202	123	20

(*) Con affondamento ridotto > Reduced embedment depth > Profondeuse d'ancrage reduites > Anwendungen mit reduzierte Verankerungstiefen

su richiesta
on demand







NWS-CEX4



Con Dado e Rondella > With Nut and Washer
 Avec Écrou et Rondelle > Mit Mutter und Scheibe



Option 7

CODICE CODE	ARTICOLO ITEM	DIAMETRO FILETTATURA THREAD DIAMETER	DIAMETRO ESTERNO ANCORANTE OUTSIDE DIAMETER OF ANCHOR	LUNGHEZZA TOTALE ANCORANTE TOTAL LENGTH OF ANCHOR	FILETTATURA DIAMETRO X LUNGHEZZA THREAD DIAMETER X LENGTH	SPESSORE FISSABILE (MAX) FIXTURE THICKNESS (MAX)	
	NWS - CEX 4	d [mm]	d _{nom} [mm]	L [mm]	dxL [mm x mm]	t _{fix} [mm]	Nr.
709281	NWS-CEX4 6x60	M6	6	60	M6 x 27	2	200
709282	NWS-CEX4 6x80	M6	6	80	M6 x 47	22	200
709284	NWS-CEX4 8x75	M8	8	75	M8 x 39	5	100
709285	NWS-CEX4 8x90	M8	8	90	M8 x 54	20	100
709286	NWS-CEX4 8x115	M8	8	115	M8 x 79	45	100
709287	NWS-CEX4 10x70 **	M10	10	70	M10 x 29	3	100
709288	NWS-CEX4 10x90	M10	10	90	M10 x 49	10	100
709289	NWS-CEX4 10x120	M10	10	120	M10 x 79	40	50
709290	NWS-CEX4 10x150	M10	10	150	M10 x 109	70	50
709292	NWS-CEX4 12x90 **	M12	12	90	M12 x 38	13	50
709293	NWS-CEX4 12x110	M12	12	110	M12 x 58	18	50
709294	NWS-CEX4 12x140	M12	12	140	M12 x 88	48	50
709296	NWS-CEX4 16x145	M16	16	145	M16 x 80	23	25
709297	NWS-CEX4 16x170	M16	16	170	M16 x 105	48	25
709299	NWS-CEX4 20x170	M20	20	170	M20 x 102	23	20
709300	NWS-CEX4 20x220	M20	20	220	M20 x 152	73	20

(**) Affondamento ridotto > Reduced embedment depth > Profondeur d'ancrage réduite > Reduzierter Verankerungstiefe



SCHEDA TECNICA TECHNICAL DATA SHEET FICHE TECHNIQUE TECHNISCHES DATENBLATT

NW-S



Con Dado e Rondella > With Nut and Washer
Avec Écrou et Rondelle > Mit Mutter und Scheibe



CODICE CODE	ARTICOLO ITEM	DIAMETRO FILETTATURA THREAD DIAMETER	DIAMETRO ESTERNO ANCORANTE OUTSIDE DIAMETER OF ANCHOR	LUNGHEZZA TOTALE ANCORANTE TOTAL LENGTH OF ANCHOR	FILETTATURA DIAMETRO X LUNGHEZZA THREAD DIAMETER X LENGTH	SPESSORE FISSABILE (MAX) FIXTURE THICKNESS (MAX)	
	NW-S	d [mm]	d _{nom} [mm]	L [mm]	dxL [mm x mm]	t _{fix} [mm]	Nr.
708900	NWS 6-45	M6	6	45	M6 x 14	2	200
708901	NWS 6-60	M6	6	60	M6 x 27	10	200
708902	NWS 6-70	M6	6	70	M6 x 37	12	200
708903	NWS 6-80	M6	6	80	M6 x 47	22	200
708904	NWS 6-90	M6	6	90	M6 x 57	32	200
708905	NWS 6-100	M6	6	100	M6 x 67	42	200
708906	NWS 6-110	M6	6	110	M6 x 77	52	200
708907	NWS 6-120	M6	6	120	M6 x 87	62	100
708908	NWS 6-130	M6	6	130	M6 x 97	72	100
708909	NWS 6-140	M6	6	140	M6 x 107	82	100
708910	NWS 6-150	M6	6	150	M6 x 117	92	100
708911	NWS 6-160	M6	6	160	M6 x 127	102	100
708912	NWS 6-170	M6	6	170	M6 x 137	112	100
708913	NWS 6-180	M6	6	180	M6 x 147	122	100
708914	NWS 8-50	M8	8	50	M8 x 17	2	200
708915	NWS 8-65	M8	8	65	M8 x 29	5	100
708916	NWS 8-75	M8	8	75	M8 x 39	10	100
708917	NWS 8-90	M8	8	90	M8 x 54	20	100
708918	NWS 8-115	M8	8	115	M8 x 79	45	100
708919	NWS 8-130	M8	8	130	M8 x 94	60	100
708920	NWS 8-155	M8	8	155	M8 x 119	85	100
708921	NWS 10-70	M10	10	70	M10 x 29	2	100
708922	NWS 10-80	M10	10	80	M10 x 39	5	100
708923	NWS 10-90	M10	10	90	M10 x 49	10	100
708924	NWS 10-100	M10	10	100	M10 x 59	20	100
708925	NWS 10-120	M10	10	120	M10 x 79	40	50
708926	NWS 10-140	M10	10	140	M10 x 99	60	50
708927	NWS 10-150	M10	10	150	M10 x 109	70	50
708928	NWS 10-170	M10	10	170	M10 x 129	90	50



CODICE CODE	ARTICOLO ITEM	DIAMETRO FILETTATURA THREAD DIAMETER	DIAMETRO ESTERNO ANCORANTE OUTSIDE DIAMETER OF ANCHOR	LUNGHEZZA TOTALE ANCORANTE TOTAL LENGTH OF ANCHOR	FILETTATURA DIAMETRO X LUNGHEZZA THREAD DIAMETER X LENGTH	SPESSORE FISSABILE (MAX) FIXTURE THICKNESS (MAX)	 Nr.
	N W - S	d [mm]	d _{nom} [mm]	L [mm]	dxL [mm x mm]	t _{fix} [mm]	
708929	NWS 10-210	M10	10	210	M10 x 169	130	50
708930	NWS 10-230	M10	10	230	M10 x 189	150	50
708931	NWS 12-80	M12	12	80	M12 x 28	2	50
708932	NWS 12-90	M12	12	90	M12 x 38	5	50
708933	NWS 12-100	M12	12	100	M12 x 48	8	50
708934	NWS 12-110	M12	12	110	M12 x 58	18	50
708935	NWS 12-120	M12	12	120	M12 x 68	28	50
708936	NWS 12-140	M12	12	140	M12 x 88	48	50
708937	NWS 12-160	M12	12	160	M12 x 108	68	50
708938	NWS 12-180	M12	12	180	M12 x 128	88	50
708939	NWS 12-220	M12	12	220	M12 x 168	128	50
708940	NWS 12-250	M12	12	250	M12 x 198	158	25
708941	NWS 14-80	M14	14	80	M14 x 25	5	50
708942	NWS 14-100	M14	14	100	M14 x 43	10	50
708943	NWS 14-120	M14	14	120	M14 x 63	12	25
708944	NWS 14-145	M14	14	145	M14 x 88	37	25
708945	NWS 14-170	M14	14	170	M14 x 113	62	25
708946	NWS 14-220	M14	14	220	M14 x 163	112	25
708947	NWS 14-250	M14	14	250	M14 x 193	142	25
708948	NWS 16-90	M16	16	90	M16 x 27	5	25
708962	NWS 16-110	M16	16	110	M16 x 27	7	25
708949	NWS 16-125	M16	16	125	M16 x 60	10	25
708950	NWS 16-145	M16	16	145	M16 x 80	23	25
708951	NWS 16-175	M16	16	175	M16 x 110	53	25
708952	NWS 16-220	M16	16	220	M16 x 155	98	25
708953	NWS 16-250	M16	16	250	M16 x 185	128	25
708954	NWS 16-280	M16	16	280	M16 x 215	158	25
708955	NWS 20-120	M20	20	120	M20 x 52	10	20
708956	NWS 20-170	M20	20	170	M20 x 102	23	20
708957	NWS 20-220	M20	20	220	M20 x 152	73	20
708958	NWS 20-270	M20	20	270	M20 x 202	123	20





SCHEDA TECNICA TECHNICAL DATA SHEET FICHE TECHNIQUE TECHNISCHES DATENBLATT

NW-X2



Con Dado e Rondella > With Nut and Washer
Avec Écrou et Rondelle > Mit Mutter und Scheibe



CODICE CODE	ARTICOLO ITEM	DIAMETRO FILETTATURA THREAD DIAMETER	DIAMETRO ESTERNO ANCORANTE OUTSIDE DIAMETER OF ANCHOR	LUNGHEZZA TOTALE ANCORANTE TOTAL LENGTH OF ANCHOR	FILETTATURA DIAMETRO X LUNGHEZZA THREAD DIAMETER X LENGTH	SPESSORE FISSABILE (MAX) FIXTURE THICKNESS (MAX)	
	N W - X 2	d [mm]	d _{nom} [mm]	L [mm]	dxL [mm x mm]	t _{fix} [mm]	Nr.
709251	NWX2 6-45	M6	6	45	M6 × 20	5	100
709252	NWX2 6-55	M6	6	55	M6 × 25	10	100
709253	NWX2 6-65	M6	6	65	M6 × 35	20	100
709255	NWX2 8-50	M8	8	50	M8 × 20	5	100
709257	NWX2 8-75	M8	8	75	M8 × 45	20	100
709264	NWX2 8-90	M8	8	90	M8 × 60	25	100
709258	NWX2 8-115	M8	8	115	M8 × 80	50	50
709259	NWX2 10-60	M10	10	60	M10 × 25	10	50
709261	NWX2 10-90	M10	10	90	M10 × 55	20	50
709263	NWX2 10-120	M10	10	120	M10 × 80	50	50
709265	NWX2 12-75	M12	12	75	M12 × 35	10	50
709267	NWX2 12-110	M12	12	110	M12 × 70	30	25
709268	NWX2 12-140	M12	12	140	M12 × 75	50	25
709266	NWX2 12-180	M12	12	180	M12 × 100	90	25
709269	NWX2 16-125	M16	16	125	M16 × 60	45	15
709271	NWX2 16-145	M16	16	145	M16 × 80	50	15
709274	NWX2 16-175	M16	16	175	M16 × 100	60	15
709275	NWX2 20-170	M20	20	170	M20 × 105	35	10
709277	NWX2 20-220	M20	20	220	M20 × 140	85	10

NW-B



Con Dado e Rondella > With Nut and Washer
Avec Écrou et Rondelle > Mit Mutter und Scheibe



CODICE CODE	ARTICOLO ITEM	DIAMETRO FILETTATURA THREAD DIAMETER	DIAMETRO ESTERNO ANCORANTE OUTSIDE DIAMETER OF ANCHOR	LUNGHEZZA TOTALE ANCORANTE TOTAL LENGTH OF ANCHOR	FILETTATURA DIAMETRO X LUNGHEZZA THREAD DIAMETER X LENGTH	SPESSORE FISSABILE (MAX) FIXTURE THICKNESS (MAX)	
	N W - B	d [mm]	d _{nom} [mm]	L [mm]	dxL [mm x mm]	t _{fix} [mm]	Nr.
709015	NWB 8-70	M8	8	70	M8 × 40	15	100
709019	NWB 8-95	M8	8	95	M8 × 65	30	100
709024	NWB 8-160	M8	8	160	M8 × 120	95	50
709026	NWB 10-60	M10	10	60	M10 × 25	10	50
709027	NWB 10-75	M10	10	75	M10 × 40	10	50
709041	NWB 10-200	M10	10	200	M10 × 150	130	25
709058	NWB 12-155	M12	12	155	M12 × 80	60	25
709063	NWB 12-240	M12	12	240	M12 × 160	150	50



CODICE CODE	ARTICOLO ITEM	DIAMETRO FILETTATURA THREAD DIAMETER	DIAMETRO ESTERNO ANCORANTE OUTSIDE DIAMETER OF ANCHOR	LUNGHEZZA TOTALE ANCORANTE TOTAL LENGTH OF ANCHOR	FILETTATURA DIAMETRO X LUNGHEZZA THREAD DIAMETER X LENGTH	SPESSORE FISSABILE (MAX) FIXTURE THICKNESS (MAX)	
	N W - B	d [mm]	d _{nom} [mm]	L [mm]	dxL [mm x mm]	t _{fix} [mm]	Nr.
708432	NWB 14-140**	M14	14	140	M14 x 90	50	25
708434	NWB 14-160**	M14	14	160	M14 x 100	70	25
709078	NWB 16-300	M16	16	300	M16 x 160	140	25
709080	NWB 16-330	M16	16	330	M16 x 160	170	20
709081	NWB 16-350	M16	16	350	M16 x 160	190	20
709082	NWB 16-360	M16	16	360	M16 x 160	200	20
709084	NWB 16-420 *	M16	16	420	M16 x 160	260	20
709085	NWB 16-550 *	M16	16	550	M16 x 160	390	20
709086	NWB 16-700 *	M16	16	700	M16 x 160	540	20
709087	NWB 16-900 *	M16	16	900	M16 x 160	740	20
709090	NWB 20-130	M20	20	130	M20 x 70	10	10
709091	NWB 20-160	M20	20	160	M20 x 100	25	10
709097	NWB 20-300	M20	20	300	M20 x 180	165	10
709098	NWB 20-395	M20	20	395	M20 x 180	260	20
708724	NWB 24-180	M24	24	180	M24 x 100	25	4
708725	NWB 24-260	M24	24	260	M24 x 100	105	4

(*) Con rondella maggiorata > With larger washer > Avec rondelle plus grande > Mit Erhöhte Scheibe

(**) Con clip in ferro > With steel clip > Avec collier acier > Mit Stahrling



TK (ex NW-CE)



Con Dado e Rondella > With Nut and Washer
Avec Écrou et Rondelle > Mit Mutter und Scheibe



Option 7

CODICE CODE	ARTICOLO ITEM	DIAMETRO FILETTATURA THREAD DIAMETER	DIAMETRO ESTERNO ANCORANTE OUTSIDE DIAMETER OF ANCHOR	LUNGHEZZA TOTALE ANCORANTE TOTAL LENGTH OF ANCHOR	FILETTATURA DIAMETRO X LUNGHEZZA THREAD DIAMETER X LENGTH	SPESSORE FISSABILE (MAX) FIXTURE THICKNESS (MAX)	
	N W - CE	d [mm]	d _{nom} [mm]	L [mm]	dxL [mm x mm]	t _{fix} [mm]	Nr.
709151	TK 12-200	M12	12	200	M12 x 115	105	50
709154	TK 12-240	M12	12	240	M12 x 115	145	50
709156	TK 12-260	M12	12	260	M12 x 115	165	30
709157	TK 12-280	M12	12	280	M12 x 115	185	30
709159	TK 12-300	M12	12	300	M12 x 150	205	30
709160	TK 12-330	M12	12	330	M12 x 150	235	30
709162	TK 12-360	M12	12	360	M12 x 150	250	30
709182	TK 16-240	M16	16	240	M16 x 115	125	25
709183	TK 16-260	M16	16	260	M16 x 115	145	25
709186	TK 16-300	M16	16	300	M16 x 150	185	25
709188	TK 16-330	M16	16	330	M16 x 150	215	25
709190	TK 16-360	M16	16	360	M16 x 150	245	25
709192	TK 16-400	M16	16	400	M16 x 150	280	20



SCHEDA TECNICA TECHNICAL DATA SHEET FICHE TECHNIQUE TECHNISCHES DATENBLATT

> Dati installazione > Installation data > Données de installation > Installationsangaben

D	h_{min} [mm]	Spessore minimo del supporto > Minimum thickness of base material > Épaisseur minimal du matière base > Mindestbauteildicke
N	d_o [mm]	Diametro foro > Hole diameter > Diamètre du trou > Bohrennennendurchmesser
E	h_1 [mm]	Profondità del foro > Hole depth > Profondeur du trou > Bohrlochtiefe
G	h_{nom} [mm]	Profondità di inserimento > Embedment depth > Profondeur d'enfocé > Setztiefe
E	h_{ef} [mm]	Profondità effettiva ancoraggio > Effective anchorage depth > Profondeur efficace d'ancrage > Effektive Verankerungstiefe
L	S_{cr} [mm]	Interasse caratteristico > Characteristic spacing > Entraxe caractéristique > Charakteristische Achsabstand
E	C_{cr} [mm]	Distanza dal bordo caratteristica > Characteristic edge distance > Distance du bord caractéristique > Charakteristische Randabstand
G	S_{min} [mm]	Interasse minimo > Minimum allowable spacing > Entraxe minimale > Minimaler Achsabstand
L	C_{min} [mm]	Distanza minima dal bordo > Minimum allowable edge distance > Distance du bord minimale > Minimaler Randabstand
E	d_r [mm]	Diametro foro spessore fissabile > Diameter of clearance hole in the fixture > Diamètre du trou de épaisseur fixable > Durchgangsloch im Anbauteil
L	S_w [mm]	Chiave > Key > Clef > Schlüsselweite
L	T_{inst} [Nm]	Coppia di serraggio > Installation torque > Couple de serrage > Drehmoment beim Verankern

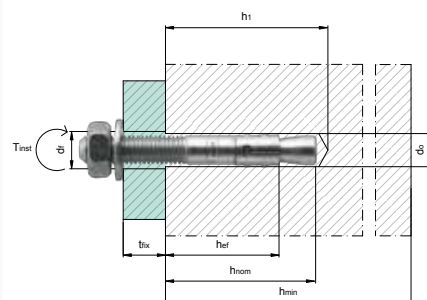

NWS-CE1



Con Dado e Rondella > With Nut and Washer
Avec Écrou et Rondelle > Mit Mutter und Scheibe



Option 1

CODICE CODE	ARTICOLO ITEM	SPESSORE MIN SUPPORTO MIN THICKNESS BASE MATERIAL	DIAM. FORO HOLE DIAM.	PROFONDITÀ DEL FORO HOLE DEPTH	PROFONDITÀ DI INSERIMENTO EMBEDMENT DEPTH	PROFONDITÀ EFFETTIVA ANCORAGGIO EFFECTIVE ANCHORAGE DEPTH	INTERASSE CARATTERISTICO CHARACTERISTIC SPACING	DISTANZA DAL BORDO CARATTERISTICA CHARACTERISTIC EDGE DISTANCE	INTERASSE MIN ALLOWABLE SPACING	DISTANZA MIN DAL BORDO MIN ALLOWABLE EDGE DISTANCE	DIAM. FORO SPESORE FISSABILE DIAM. CLEARANCE HOLE IN THE FIXTURE	CHIAVE KEY	COPIA DI SERRAGGIO INSTALLATION TORQUE
CE	NWS-CE1	h_{min} [mm]	d_o [mm]	h_1 [mm]	h_{nom} [mm]	h_{ef} [mm]	S_{cr} [mm]	C_{cr} [mm]	S_{min} [mm]	C_{min} [mm]	d_r [mm]	S_w [mm]	T_{inst} [Nm]
708971	NWS-CE1 8-75	100	8	60	55	48	114	72	75	75	9	13	20
708972	NWS-CE1 8-95	100	8	60	55	48	114	72	75	75	9	13	20
708973	NWS-CE1 8-115	100	8	60	55	48	114	72	75	75	9	13	20
708975	NWS-CE1 10-90	120	10	75	68	60	151	90	90	90	12	17	40
708976	NWS-CE1 10-105	120	10	75	68	60	151	90	90	90	12	17	40
708977	NWS-CE1 10-115	120	10	75	68	60	151	90	90	90	12	17	40
708978	NWS-CE1 10-135	120	10	75	68	60	151	90	90	90	12	17	40
708979	NWS-CE1 10-165	120	10	75	68	60	151	90	90	90	12	17	40
708980	NWS-CE1 10-185	120	10	75	68	60	151	90	90	90	12	17	40
708984	NWS-CE1 12-110	140	12	85	80	70	175	105	105	105	14	19	60
708985	NWS-CE1 12-120	140	12	85	80	70	175	105	105	105	14	19	60
708986	NWS-CE1 12-130	140	12	85	80	70	175	105	105	105	14	19	60
708987	NWS-CE1 12-150	140	12	85	80	70	175	105	105	105	14	19	60
708988	NWS-CE1 12-180	140	12	85	80	70	175	105	105	105	14	19	60
708989	NWS-CE1 12-200	140	12	85	80	70	175	105	105	105	14	19	60
708992	NWS-CE1 16-145	170	16	105	97	85	213	128	130	130	18	24	100
708993	NWS-CE1 16-175	170	16	105	97	85	213	128	130	130	18	24	100
708994	NWS-CE1 16-220	170	16	105	97	85	213	128	130	130	18	24	100
708995	NWS-CE1 16-250	170	16	105	97	85	213	128	130	130	18	24	100
708996	NWS-CE1 20-170	200	20	125	114	100	250	150	150	150	22	30	200
708997	NWS-CE1 20-200	200	20	125	114	100	250	150	150	150	22	30	200



NWS-CE

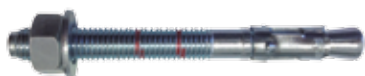

Con Dado e Rondella > With Nut and Washer
Avec Écrou et Rondelle > Mit Mutter und Scheibe



Option 7

CODICE CODE	ARTICOLO ITEM	SPESSORE MIN SUPPORTO MIN THICKNESS BASE MATERIAL	DIAM. FORO HOLE DIAM.	PROFONDITÀ DEL FORO HOLE DEPTH	PROFONDITÀ DI INSERIMENTO EMBEDMENT DEPTH	PROFONDITÀ EFFETTIVA ANCORAGGIO EFFECTIVE ANCHORAGE DEPTH	INTERASSE CARATTERISTICO CHARACTERISTIC SPACING	DISTANZA DAL BORDO CARATTERISTICA CHARACTERISTIC EDGE DISTANCE	INTERASSE MIN ALLOWABLE SPACING	DISTANZA MIN DAL BORDO MIN ALLOWABLE EDGE DISTANCE	DIAM. FORO SPESORE FISSABILE DIAM. CLEARANCE HOLE IN THE FIXTURE	CHIAVE KEY	COPPIA DI SERRAGGIO INSTALLATION TORQUE
CE	NWS-CE	h _{min} [mm]	d _o [mm]	h _i [mm]	h _{nom} [mm]	h _{ef} [mm]	S _{cr} [mm]	C _{cr} [mm]	S _{min} [mm]	C _{min} [mm]	d _f [mm]	S _w [mm]	T _{inst} [Nm]
709200	NWS-CE 6-60	100	6	55	50	40	120	60	50	50	7	10	7
709201	NWS-CE 6-70	100	6	55	50	40	120	60	50	50	7	10	7
709202	NWS-CE 6-80	100	6	55	50	40	120	60	50	50	7	10	7
709203	NWS-CE 6-90	100	6	55	50	40	120	60	50	50	7	10	7
709204	NWS-CE 6-100	100	6	55	50	40	120	60	50	50	7	10	7
709205	NWS-CE 6-110	100	6	55	50	40	120	60	50	50	7	10	7
709206	NWS-CE 6-120	100	6	55	50	40	120	60	50	50	7	10	7
709207	NWS-CE 6-130	100	6	55	50	40	120	60	50	50	7	10	7
709208	NWS-CE 6-140	100	6	55	50	40	120	60	50	50	7	10	7
709209	NWS-CE 8-60 *	100	8	50	47	35	105	53	65	65	9	13	20
709210	NWS-CE 8-75	100	8	65	60	48	144	72	65	65	9	13	20
709211	NWS-CE 8-90	100	8	65	60	48	144	72	65	65	9	13	20
709212	NWS-CE 8-115	100	8	65	60	48	144	72	65	65	9	13	20
709213	NWS-CE 8-130	100	8	65	60	48	144	72	65	65	9	13	20
709214	NWS-CE 10-70 *	100	10	60	54	42	126	63	70	70	12	17	35
709215	NWS-CE 10-80 *	100	10	60	54	42	126	63	70	70	12	17	35
709216	NWS-CE 10-90	110	10	75	67	55	165	83	70	70	12	17	35
709217	NWS-CE 10-100	110	10	75	67	55	165	83	70	70	12	17	35
709218	NWS-CE 10-120	110	10	75	67	55	165	83	70	70	12	17	35
709219	NWS-CE 10-150	110	10	75	67	55	165	83	70	70	12	17	35
709220	NWS-CE 10-170	110	10	75	67	55	165	83	70	70	12	17	35
709221	NWS-CE 10-210	110	10	75	67	55	165	83	70	70	12	17	35
709222	NWS-CE 10-230	110	10	75	67	55	165	83	70	70	12	17	35
709224	NWS-CE 12-90 *	100	12	70	62	50	150	75	85	85	14	19	60
709225	NWS-CE 12-100 *	100	12	70	62	50	150	75	85	85	14	19	60
709226	NWS-CE 12-110	130	12	85	77	65	195	98	85	85	14	19	60
709227	NWS-CE 12-120	130	12	85	77	65	195	98	85	85	14	19	60
709228	NWS-CE 12-140	130	12	85	77	65	195	98	85	85	14	19	60
709229	NWS-CE 12-160	130	12	85	77	65	195	98	85	85	14	19	60
709230	NWS-CE 12-180	130	12	85	77	65	195	98	85	85	14	19	60
709231	NWS-CE 12-220	130	12	85	77	65	195	98	85	85	14	19	60
709232	NWS-CE 12-250	130	12	85	77	65	195	98	85	85	14	19	60
709233	NWS-CE 14-120	150	14	100	91	75	225	113	100	100	16	22	90
709234	NWS-CE 14-145	150	14	100	91	75	225	113	100	100	16	22	90
709235	NWS-CE 14-170	150	14	100	91	75	225	113	100	100	16	22	90
709236	NWS-CE 14-220	150	14	100	91	75	225	113	100	100	16	22	90
709237	NWS-CE 14-250	150	14	100	91	75	225	113	100	100	16	22	90
709238	NWS-CE 16-125	168	16	110	104	84	252	126	110	110	18	24	120
709239	NWS-CE 16-145	168	16	110	104	84	252	126	110	110	18	24	120
709240	NWS-CE 16-175	168	16	110	104	84	252	126	110	110	18	24	120
709241	NWS-CE 16-220	168	16	110	104	84	252	126	110	110	18	24	120
709242	NWS-CE 16-250	168	16	110	104	84	252	126	110	110	18	24	120
709243	NWS-CE 16-280	168	16	110	104	84	252	126	110	110	18	24	120
709244	NWS-CE 20-170	206	20	135	125	103	309	155	135	135	22	30	240
709245	NWS-CE 20-220	206	20	135	125	103	309	155	135	135	22	30	240
709246	NWS-CE 20-270	206	20	135	125	103	309	155	135	135	22	30	240

(* Con affondamento ridotto > Reduced embedment depth > Profondeuse d'ancrage reduites > Anwendungen mit reduzierte Verankerungstiefen

su richiesta
on demand





SCHEDA TECNICA TECHNICAL DATA SHEET FICHE TECHNIQUE TECHNISCHES DATENBLATT

NWS-CEX4



Con Dado e Rondella > With Nut and Washer
Avec Écrou et Rondelle > Mit Mutter und Scheibe



Option 7

CODICE CODE	ARTICOLO ITEM	SPESSORE MIN SUPPORTO MIN THICKNESS BASE MATERIAL	DIAM. FORO HOLE DIAM.	PROFONDITÀ DEL FORO HOLE DEPTH	PROFONDITÀ DI INSERIMENTO EMBEDMENT DEPTH	PROFONDITÀ EFFETTIVA ANCORAGGIO EFFECTIVE ANCHORAGE DEPTH	INTERASSE CARATTERISTICO CHARACTERISTIC SPACING	DISTANZA DAL BORDO CARATTERISTICA CHARACTERISTIC EDGE DISTANCE	INTERASSE MIN ALLOWABLE SPACING	DISTANZA MIN DAL BORDO MIN ALLOWABLE EDGE DISTANCE	DIAM. FORO SPESSORE FISSABILE DIAM. CLEARANCE HOLE IN THE FIXTURE	CHIAVE KEY	COPPIA DI SERRAGGIO INSTALLATION TORQUE
CE	NWS-CE	h_{min} [mm]	d_0 [mm]	h_1 [mm]	h_{nom} [mm]	h_{ef} [mm]	S_{cr} [mm]	C_{cr} [mm]	S_{min} [mm]	C_{min} [mm]	d_f [mm]	S_w [mm]	T_{inst} [Nm]
709281	NWS-CEX4 6x60	100	6	55	50	40	120	60	50	50	7	10	7
709282	NWS-CEX4 6x80	100	6	55	50	40	120	60	50	50	7	10	7
709284	NWS-CEX4 8x75	100	8	65	60	48	144	72	65	65	9	13	20
709285	NWS-CEX4 8x90	100	8	65	60	48	144	72	65	65	9	13	20
709286	NWS-CEX4 8x115	100	8	65	60	48	144	72	65	65	9	13	20
709287	NWS-CEX4 10x70 **	100	10	60	54	42	126	63	70	70	12	17	35
709288	NWS-CEX4 10x90	110	10	75	67	55	165	83	70	70	12	17	35
709289	NWS-CEX4 10x120	110	10	75	67	55	165	83	70	70	12	17	35
709290	NWS-CEX4 10x150	110	10	75	67	55	165	83	70	70	12	17	35
709292	NWS-CEX4 12x90 **	100	12	70	62	50	150	75	85	85	14	19	60
709293	NWS-CEX4 12x110	130	12	85	77	65	195	98	85	85	14	19	60
709294	NWS-CEX4 12x140	130	12	85	77	65	195	98	85	85	14	19	60
709296	NWS-CEX4 16x145	168	16	110	104	84	252	126	110	110	18	24	120
709297	NWS-CEX4 16x170	168	16	110	104	84	252	126	110	110	18	24	120
709299	NWS-CEX4 20x170	206	20	135	125	103	309	155	135	135	22	30	240
709300	NWS-CEX4 20x220	206	20	135	125	103	309	155	135	135	22	30	240

(**) Con affondamento ridotto > Reduced embedment depth > Profondeuse d'ancrage reduites > Anwendungen mit reduzierte Verankerungstiefen

NW-S



Con Dado e Rondella > With Nut and Washer
Avec Écrou et Rondelle > Mit Mutter und Scheibe



CODICE CODE	ARTICOLO ITEM	SPESSORE MIN SUPPORTO MIN THICKNESS BASE MATERIAL	DIAM. FORO HOLE DIAM.	PROFONDITÀ DEL FORO HOLE DEPTH	PROFONDITÀ DI INSERIMENTO EMBEDMENT DEPTH	PROFONDITÀ EFFETTIVA ANCORAGGIO EFFECTIVE ANCHORAGE DEPTH	INTERASSE CARATTERISTICO CHARACTERISTIC SPACING	DISTANZA DAL BORDO CARATTERISTICA CHARACTERISTIC EDGE DISTANCE	INTERASSE MIN ALLOWABLE SPACING	DISTANZA MIN DAL BORDO MIN ALLOWABLE EDGE DISTANCE	DIAM. FORO SPESSORE FISSABILE DIAM. CLEARANCE HOLE IN THE FIXTURE	CHIAVE KEY	COPPIA DI SERRAGGIO INSTALLATION TORQUE
	NW-S	h_{min} [mm]	d_0 [mm]	h_1 [mm]	h_{nom} [mm]	h_{ef} [mm]	S_{cr} [mm]	C_{cr} [mm]	S_{min} [mm]	C_{min} [mm]	d_f [mm]	S_w [mm]	T_{inst} [Nm]
708900	NWS 6-45	80	6	40	35	25	80	80	40	40	7	10	7
708901	NWS 6-60	100	6	47	42	32	100	100	50	50	7	10	7
708902	NWS 6-70	100	6	55	50	40	120	60	50	50	7	10	7
708903	NWS 6-80	100	6	55	50	40	120	60	50	50	7	10	7
708904	NWS 6-90	100	6	55	50	40	120	60	50	50	7	10	7



CODICE CODE	ARTICOLO ITEM	SPESORE MIN SUPPORTO MIN THICKNESS BASE MATERIAL	DIAM. FORO HOLE DIAM.	PROFONDITÀ DEL FORO HOLE DEPTH	PROFONDITÀ DI INSERIMENTO EMBEDMENT DEPTH	PROFONDITÀ EFFETTIVA ANCORAGGIO EFFECTIVE ANCHORAGE DEPTH	INTERASSE CARATTERISTICO CHARACTERISTIC SPACING	DISTANZA DAL BORDO CARATTERISTICA CHARACTERISTIC EDGE DISTANCE	INTERASSE MIN ALLOWABLE SPACING	DISTANZA MIN DAL BORDO MIN ALLOWABLE EDGE DISTANCE	DIAM. FORO SPESSORE FISSABILE DIAM. CLEARANCE HOLE IN THE FIXTURE	CHIAVE KEY	COPIA DI SERRAGGIO INSTALLATION TORQUE
	N W - S	h_{min} [mm]	d₀ [mm]	h₁ [mm]	h_{nom} [mm]	h_{ef} [mm]	S_{cr} [mm]	C_{cr} [mm]	S_{min} [mm]	C_{min} [mm]	d_f [mm]	S_w [mm]	T_{inst} [Nm]
708905	NWS 6-100	100	6	55	50	40	120	60	50	50	7	10	7
708906	NWS 6-110	100	6	55	50	40	120	60	50	50	7	10	7
708907	NWS 6-120	100	6	55	50	40	120	60	50	50	7	10	7
708908	NWS 6-130	100	6	55	50	40	120	60	50	50	7	10	7
708909	NWS 6-140	100	6	55	50	40	120	60	50	50	7	10	7
708910	NWS 6-150	100	6	55	50	40	120	60	50	50	7	10	7
708911	NWS 6-160	100	6	55	50	40	120	60	50	50	7	10	7
708912	NWS 6-170	100	6	55	50	40	120	60	50	50	7	10	7
708913	NWS 6-180	100	6	55	50	40	120	60	50	50	7	10	7
708914	NWS 8-50	80	8	43	38	26	144	72	40	40	9	13	20
708915	NWS 8-65	100	8	55	50	38	144	100	50	50	9	13	20
708916	NWS 8-75	100	8	60	55	43	144	100	65	65	9	13	20
708917	NWS 8-90	100	8	65	60	48	144	72	65	65	9	13	20
708918	NWS 8-115	100	8	65	60	48	144	72	65	65	9	13	20
708919	NWS 8-130	100	8	65	60	48	144	72	65	65	9	13	20
708920	NWS 8-155	100	8	65	60	48	144	72	65	65	9	13	20
708921	NWS 10-70	100	10	63	55	43	165	100	65	65	12	17	35
708922	NWS 10-80	110	10	70	62	50	165	110	70	70	12	17	35
708923	NWS 10-90	110	10	75	67	55	165	83	70	70	12	17	35
708924	NWS 10-100	110	10	75	67	55	165	83	70	70	12	17	35
708925	NWS 10-120	110	10	75	67	55	165	83	70	70	12	17	35
708926	NWS 10-140	110	10	75	67	55	165	83	70	70	12	17	35
708927	NWS 10-150	110	10	75	67	55	165	83	70	70	12	17	35
708928	NWS 10-170	110	10	75	67	55	165	83	70	70	12	17	35
708929	NWS 10-210	110	10	75	67	55	165	83	70	70	12	17	35
708930	NWS 10-230	110	10	75	67	55	165	83	70	70	12	17	35
708931	NWS 12-80	110	12	71	63	51	195	110	70	70	14	19	60
708932	NWS 12-90	130	12	78	70	58	195	120	85	85	14	19	60
708933	NWS 12-100	130	12	85	77	65	195	98	85	85	14	19	60
708934	NWS 12-110	130	12	85	77	65	195	98	85	85	14	19	60
708935	NWS 12-120	130	12	85	77	65	195	98	85	85	14	19	60
708936	NWS 12-140	130	12	85	77	65	195	98	85	85	14	19	60
708937	NWS 12-160	130	12	85	77	65	195	98	85	85	14	19	60
708938	NWS 12-180	130	12	85	77	65	195	98	85	85	14	19	60
708939	NWS 12-220	130	12	85	77	65	195	98	85	85	14	19	60
708940	NWS 12-250	130	12	85	77	65	195	98	85	85	14	19	60



SCHEDA TECNICA TECHNICAL DATA SHEET FICHE TECHNIQUE TECHNISCHES DATENBLATT

CODICE CODE	ARTICOLO ITEM	SPESORE MIN SUPPORTO MIN THICKNESS BASE MATERIAL	DIAM. FORO HOLE DIAM.	PROFONDITÀ DEL FORO HOLE DEPTH	PROFONDITÀ DI INSERIMENTO EMBEDMENT DEPTH	PROFONDITÀ EFFETTIVA ANCORAGGIO EFFECTIVE ANCHORAGE DEPTH	INTERASSE CARATTERISTICO CHARACTERISTIC SPACING	DISTANZA DAL BORDO CARATTERISTICA CHARACTERISTIC EDGE DISTANCE	INTERASSE MIN ALLOWABLE SPACING	DISTANZA MIN DAL BORDO MIN ALLOWABLE EDGE DISTANCE	DIAM. FORO SPESORE FISSABILE DIAM. CLEARANCE HOLE IN THE FIXTURE	CHIAVE KEY	COPIA DI SERRAGGIO INSTALLATION TORQUE
	N W - S	h_{min} [mm]	d_o [mm]	h_1 [mm]	h_{nom} [mm]	h_{ef} [mm]	S_{cr} [mm]	C_{cr} [mm]	S_{min} [mm]	C_{min} [mm]	d_f [mm]	S_w [mm]	T_{inst} [Nm]
708941	NWS 14-80	130	14	67	58	42	225	120	85	85	16	22	90
708942	NWS 14-100	130	14	82	73	57	225	120	85	85	16	22	90
708943	NWS 14-120	150	14	100	91	75	225	113	100	100	16	22	90
708944	NWS 14-145	150	14	100	91	75	225	113	100	100	16	22	90
708945	NWS 14-170	150	14	100	91	75	225	113	100	100	16	22	90
708946	NWS 14-220	150	14	100	91	75	225	113	100	100	16	22	90
708947	NWS 14-250	150	14	100	91	75	225	113	100	100	16	22	90
708948	NWS 16-90	150	16	73	67	47	252	140	100	100	18	24	120
708962	NWS 16-110	168	16	91	85	65	252	150	110	110	18	24	120
708949	NWS 16-125	168	16	103	97	77	252	160	110	110	18	24	120
708950	NWS 16-145	168	16	110	104	84	252	126	110	110	18	24	120
708951	NWS 16-175	168	16	110	104	84	252	126	110	110	18	24	120
708952	NWS 16-220	168	16	110	104	84	252	126	110	110	18	24	120
708953	NWS 16-250	168	16	110	104	84	252	126	110	110	18	24	120
708954	NWS 16-280	168	16	110	104	84	252	126	110	110	18	24	120
708955	NWS 20-120	168	20	98	88	66	309	155	110	110	22	30	240
708956	NWS 20-170	206	20	135	125	103	309	155	135	135	22	30	240
708957	NWS 20-220	206	20	135	125	103	309	155	135	135	22	30	240
708958	NWS 20-270	206	20	135	125	103	309	155	135	135	22	30	240

NW-X2



Con Dado e Rondella > With Nut and Washer
Avec Écrou et Rondelle > Mit Mutter und Scheibe



CODICE CODE	ARTICOLO ITEM	SPESORE MIN SUPPORTO MIN THICKNESS BASE MATERIAL	DIAM. FORO HOLE DIAM.	PROFONDITÀ DEL FORO HOLE DEPTH	PROFONDITÀ DI INSERIMENTO EMBEDMENT DEPTH	PROFONDITÀ EFFETTIVA ANCORAGGIO EFFECTIVE ANCHORAGE DEPTH	INTERASSE CARATTERISTICO CHARACTERISTIC SPACING	DISTANZA DAL BORDO CARATTERISTICA CHARACTERISTIC EDGE DISTANCE	INTERASSE MIN ALLOWABLE SPACING	DISTANZA MIN DAL BORDO MIN ALLOWABLE EDGE DISTANCE	DIAM. FORO SPESORE FISSABILE DIAM. CLEARANCE HOLE IN THE FIXTURE	CHIAVE KEY	COPIA DI SERRAGGIO INSTALLATION TORQUE
	N W - X 2	h_{min} [mm]	d_o [mm]	h_1 [mm]	h_{nom} [mm]	h_{ef} [mm]	S_{cr} [mm]	C_{cr} [mm]	S_{min} [mm]	C_{min} [mm]	d_f [mm]	S_w [mm]	T_{inst} [Nm]
709251	NWX2 6-45	80	6	38	33	25	99	49,5	45	45	7	10	6
709252	NWX2 6-55	100	6	43	38	31	114	57	46,5	46,5	7	10	6
709253	NWX2 6-65	100	6	43	38	31	114	57	46,5	46,5	7	10	10
709255	NWX2 8-50	80	8	45	35	25	105	52,5	45	45	9	13	12
709257	NWX2 8-75	100	8	55	45	35	135	67,5	52,5	52,5	9	13	15
709264	NWX2 8-90	100	8	65	55	45	165	82,5	67,5	67,5	9	13	15
709258	NWX2 8-115	100	8	65	55	45	165	82,5	67,5	67,5	9	13	15
709259	NWX2 10-60	90	10	45	35	20	105	52,5	45	45	12	17	20
709261	NWX2 10-90	120	10	65	55	40	165	82,5	60	60	12	17	30
709263	NWX2 10-120	120	10	65	55	40	165	82,5	60	60	12	17	30
709265	NWX2 12-75	100	12	60	50	33	150	75	49,5	49,5	14	19	40
709267	NWX2 12-110	130	12	70	65	48	195	97,5	72	72	14	19	50
709268	NWX2 12-140	140	12	85	75	58	225	112,5	87	87	14	19	50



CODICE CODE	ARTICOLO ITEM	SPESORE MIN SUPPORTO MIN THICKNESS BASE MATERIAL	DIAM. FORO HOLE DIAM.	PROFONDITÀ DEL FORO HOLE DEPTH	PROFONDITÀ DI INSERIMENTO EMBEDMENT DEPTH	PROFONDITÀ EFFETTIVA ANCORAGGIO EFFECTIVE ANCHORAGE DEPTH	INTERASSE CARATTERISTICO CHARACTERISTIC SPACING	DISTANZA DAL BORDO CARATTERISTICA CHARACTERISTIC EDGE DISTANCE	INTERASSE MIN ALLOWABLE SPACING	DISTANZA MIN DAL BORDO MIN ALLOWABLE EDGE DISTANCE	DIAM. FORO SPESORE FISSABILE DIAM. CLEARANCE HOLE IN THE FIXTURE	CHIAVE KEY	COPIA DI SERRAGGIO INSTALLATION TORQUE
709266	NWX2 12-180	140	12	85	75	58	225	112,5	87	87	14	19	50
709269	NWX2 16-125	120	16	70	60	40	180	90	60	60	18	24	100
709271	NWX2 16-145	150	16	85	75	60	225	112,5	90	90	18	24	100
709274	NWX2 16-175	180	16	105	95	75	285	142,5	112,5	112,5	18	24	100
709275	NWX2 20-170	200	20	120	110	85	330	165	127,5	127,5	22	30	180
709277	NWX2 20-220	200	20	120	110	85	330	165	127,5	127,5	22	30	180

NW-B



Con Dado e Rondella > With Nut and Washer
Avec Écrou et Rondelle > Mit Mutter und Scheibe



CODICE CODE	ARTICOLO ITEM	SPESORE MIN SUPPORTO MIN THICKNESS BASE MATERIAL	DIAM. FORO HOLE DIAM.	PROFONDITÀ DEL FORO HOLE DEPTH	PROFONDITÀ DI INSERIMENTO EMBEDMENT DEPTH	PROFONDITÀ EFFETTIVA ANCORAGGIO EFFECTIVE ANCHORAGE DEPTH	INTERASSE CARATTERISTICO CHARACTERISTIC SPACING	DISTANZA DAL BORDO CARATTERISTICA CHARACTERISTIC EDGE DISTANCE	INTERASSE MIN ALLOWABLE SPACING	DISTANZA MIN DAL BORDO MIN ALLOWABLE EDGE DISTANCE	DIAM. FORO SPESORE FISSABILE DIAM. CLEARANCE HOLE IN THE FIXTURE	CHIAVE KEY	COPIA DI SERRAGGIO INSTALLATION TORQUE
N W - B		h_{min} [mm]	d_o [mm]	h_i [mm]	h_{nom} [mm]	h_{ef} [mm]	S_{cr} [mm]	C_{cr} [mm]	S_{min} [mm]	C_{min} [mm]	d_f [mm]	S_w [mm]	T_{inst} [Nm]
709015	NWB 8-70	100	8	55	45	35	135	67,5	52,5	52,5	9	13	15
709019	NWB 8-95	100	8	65	55	45	165	82,5	67,5	67,5	9	13	15
709024	NWB 8-160	100	8	65	55	45	165	82,5	67,5	67,5	9	13	15
709026	NWB 10-60	90	10	45	35	20	105	52,5	45	45	12	17	20
709027	NWB 10-75	105	10	60	50	35	150	75	52,5	52,5	12	17	20
709041	NWB 10-200	120	10	65	55	40	165	82,5	60	60	12	17	30
709058	NWB 12-155	140	12	85	75	58	225	112,5	87	87	14	19	50
709063	NWB 12-240	140	12	85	75	58	225	112,5	87	87	14	19	50
708432	NWB 14-140**	140	14	85	75	58	225	112,5	87	87	16	21	70
708434	NWB 14-160**	140	14	85	75	58	225	112,5	87	87	16	21	70
709078	NWB 16-300	200	16	150	140	120	420	210	180	180	18	24	100
709080	NWB 16-330	200	16	150	140	120	420	210	180	180	18	24	100
709081	NWB 16-350	200	16	150	140	120	420	210	180	180	18	24	100
709082	NWB 16-360	200	16	150	140	120	420	210	180	180	18	24	100
709084	NWB 16-420 *	200	16	150	140	120	420	210	180	180	18	24	100
709085	NWB 16-550 *	200	16	150	140	120	420	210	180	180	18	24	100
709086	NWB 16-700 *	200	16	150	140	120	420	210	180	180	18	24	100
709087	NWB 16-900 *	200	16	150	140	120	420	210	180	180	18	24	100
709090	NWB 20-130	200	20	105	95	70	285	142,5	105	105	22	30	180
709091	NWB 20-160	200	20	120	110	85	330	165	127,5	127,5	22	30	180
709097	NWB 20-300	200	20	120	110	85	330	165	127,5	127,5	22	30	180
709098	NWB 20-395	200	20	120	110	85	330	165	127,5	127,5	22	30	180
708724	NWB 24-180	240	24	150	125	100	520	240	290	115	26	36	320
708725	NWB 24-260	240	24	150	125	100	520	240	290	115	26	36	320

(*) Con rondella maggiorata > With larger washer > Avec rondelle plus grande > Mit Erhöhte Scheiben

(**) Con clip in ferro > With steel clip > Avec collier acier > Mit Stahlring



SCHEDA TECNICA TECHNICAL DATA SHEET FICHE TECHNIQUE TECHNISCHES DATENBLATT

TK (ex NW-CE)



Con Dado e Rondella > With Nut and Washer
Avec Écrou et Rondelle > Mit Mutter und Scheibe



CODICE CODE	ARTICOLO ITEM	SPESSORE MIN SUPPORTO MIN THICKNESS BASE MATERIAL	DIAM. FORO HOLE DIAM.	PROFONDITÀ DEL FORO HOLE DEPTH	PROFONDITÀ DI INSERIMENTO EMBEDMENT DEPTH	PROFONDITÀ EFFETTIVA ANCORAGGIO EFFECTIVE ANCHORAGE DEPTH	INTERASSE CARATTERISTICO CHARACTERISTIC SPACING	DISTANZA DAL BORDO CARATTERISTICA CHARACTERISTIC EDGE DISTANCE	INTERASSE MIN ALLOWABLE SPACING	DISTANZA MIN DAL BORDO MIN ALLOWABLE EDGE DISTANCE	DIAM. FORO SPESSORE FISSABILE DIAM. CLEARANCE HOLE IN THE FIXTURE	CHIAVE KEY	COPPIA DI SERRAGGIO INSTALLATION TORQUE
CE	TK	h_{min} [mm]	d_0 [mm]	h_1 [mm]	h_{nom} [mm]	h_{ef} [mm]	S_{cr} [mm]	C_{cr} [mm]	S_{min} [mm]	C_{min} [mm]	d_f [mm]	S_w [mm]	T_{inst} [Nm]
709151	TK 12-200	160	12	95	80	75	210	105	60	80	14	19	50
709154	TK 12-240	160	12	95	80	75	210	105	60	80	14	19	50
709156	TK 12-260	160	12	95	80	75	210	105	60	80	14	19	50
709157	TK 12-280	160	12	95	80	75	210	105	60	80	14	19	50
709159	TK 12-300	160	12	95	80	75	210	105	60	80	14	19	50
709160	TK 12-330	160	12	95	80	75	210	105	60	80	14	19	50
709162	TK 12-360	160	12	95	80	75	210	105	60	80	14	19	50
709182	TK 16-240	200	16	120	100	92,8	270	135	96	128	18	24	100
709183	TK 16-260	200	16	120	100	92,8	270	135	96	128	18	24	100
709186	TK 16-300	200	16	120	100	92,8	270	135	96	128	18	24	100
709188	TK 16-330	200	16	120	100	92,8	270	135	96	128	18	24	100
709190	TK 16-360	200	16	120	100	92,8	270	135	96	128	18	24	100
709192	TK 16-400	200	16	120	100	92,8	270	135	96	128	18	24	100



> **Dati carico > Load data > Données de charge > Lastdaten**

D	$f_{ck}/f_{ck,cube}$ [N/mm ²]	Classe calcestruzzo > Concrete > Beton > Beton
N	N_{Rum} [kN]	Carico ultimo medio a trazione > Average ultimate tension load > Charge maximum moyenne de traction > Durchschnittliche Zuglast
V	V_{Rum} [kN]	Carico ultimo medio a taglio > Average ultimate shear load > Charge maximum moyenne de cisaillement > Durchschnittliche Querlast
N	N_{rec} [kN]	Carico ammissibile a trazione > Admissible tensile load > Charge admissible de traction > Zulässige Zuglast
V	V_{rec} [kN]	Carico ammissibile a taglio > Admissible shear load > Charge admissible de cisaillement > Zulässige Querlast
M	M_{rec} [Nm]	Momento flettente ammissibile > Admissible bending moment > Moment fléchissant conseillé > Empfohlene Biegemoment

OPTION 1

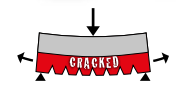

- > Carichi validi per singolo ancorante senza influenza di interasse e distanza dal bordo e $h \geq 2h_{ef}$ > 1kN = 100 Kg
- > Loads for single anchor with no influence of spacing and edge distance and with $h \geq 2h_{ef}$
- > Charges valables pour chaque ancrage sans influence d'interaxe et distance du bord et $h \geq 2h_{ef}$
- > Passende Ringe für den einzelnen Veranker, ohne Achsenabstandseinfluss und des Randabstands und $h \geq 2h_{ef}$

- > Azione di taglio non diretta verso il bordo > Coefficiente di sicurezza globale incluso > Coefficiente lato carichi utilizzato = 1,4
- > Shear directed away from the edge > General safety factor included > Load increasing safety coefficient used = 1,4
- > Action de cisaillement pas dirigée vers le bord > Coefficient de sécurité generale inclu > Coefficient côté charge utilisé = 1,4
- > Queraktion nicht an den Rand gerichtet > Generelle Sicherheitskoeffizient inbegriffen > Verwendeter Lasterhöhungssicherheitskoeffizient = 1,4

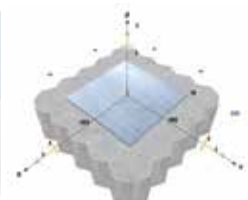

NWS-CE1

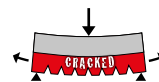

Omologato CE Opzione 1 > Approved CE Option 1
Homologué CE Option 1 > Zulassung CE Option 1

ARTICOLO ITEM	CLASSE CALCESTRUZZO CONCRETE	CARICO ULTIMO MEDIO A TRAZIONE AVERAGE ULTIMATE TENSION LOAD	CARICO ULTIMO MEDIO A TAGLIO AVERAGE ULTIMATE SHEAR LOAD	CARICO AMMISSIBILE A TRAZIONE ADMISSIBLE TENSILE LOAD	CARICO AMMISSIBILE A TAGLIO ADMISSIBLE SHEAR LOAD	MOMENTO FLETTENTE AMMISSIBILE ADMISSIBLE BENDING MOMENT
	$f_{ck}/f_{ck,cube}$ [N/mm ²]	N_{Rum} [kN]	V_{Rum} [kN]	N_{rec} [kN]	V_{rec} [kN]	M_{rec} [Nm]
NWS-CE1 8	C20/25	6,8	6,8	2,0	2,4	12,9
NWS-CE1 10	C20/25	13,4	19,6	3,6	9,3	25,6
NWS-CE1 12	C20/25	18,7	25,2	4,8	12,0	44,9
NWS-CE1 16	C20/25	33,8	45,8	9,9	21,8	114,2
NWS-CE1 20	C20/25	42,3	72,2	11,9	34,4	222,5

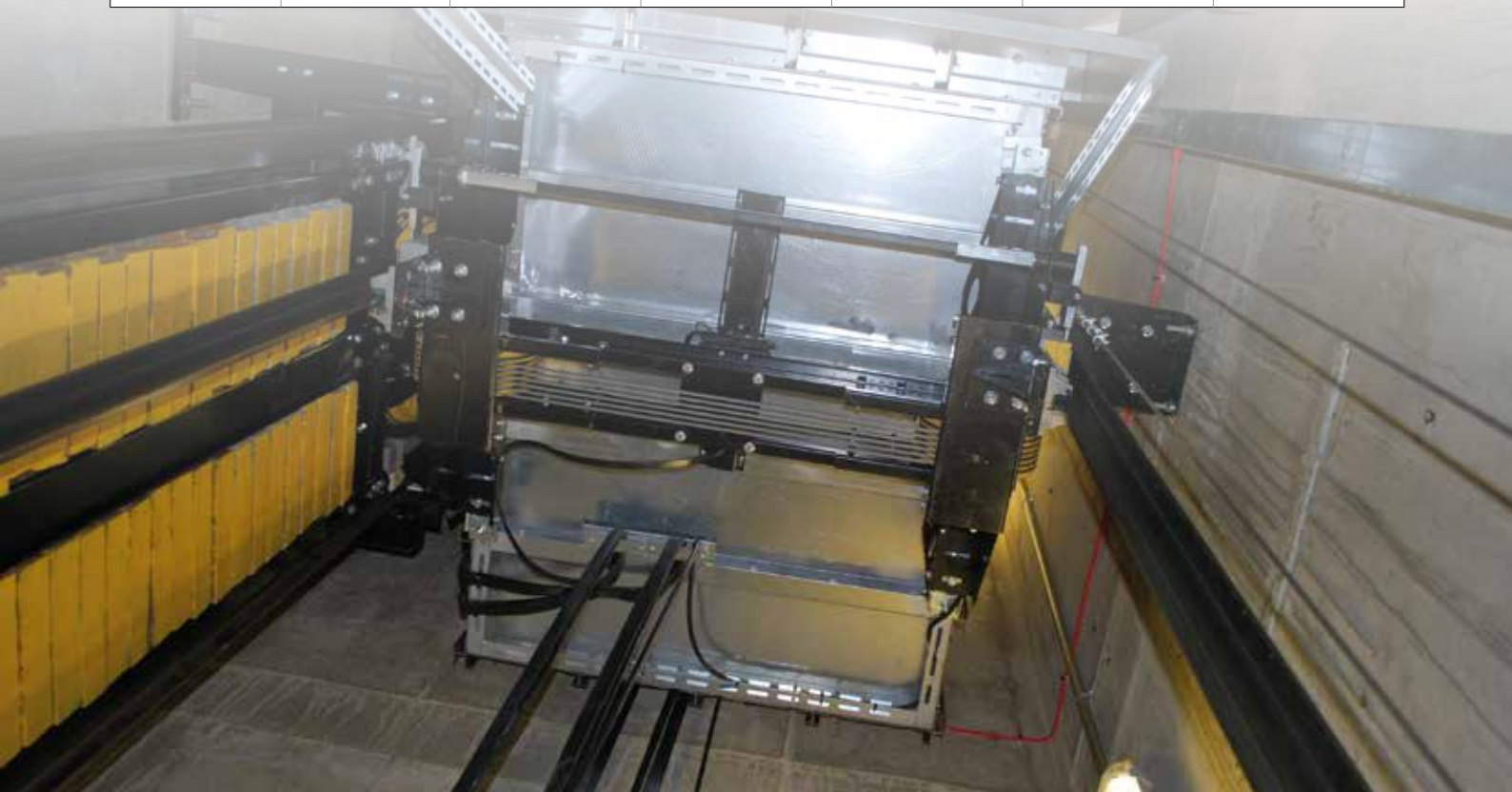



SCHEDA TECNICA TECHNICAL DATA SHEET FICHE TECHNIQUE TECHNISCHES DATENBLATT

> Dati carico > Load data > Données de charge > Lastdaten

L	$f_{ck}/f_{ck,cube}$ [N/mm ²]	Classe calcestruzzo > Concrete > Beton > Beton
E	N_{Rum} [kN]	Carico ultimo medio a trazione > Average ultimate tension load > Charge maximum moyenne de traction > Durchschnittliche Zuglast
N	V_{Rum} [kN]	Carico ultimo medio a taglio > Average ultimate shear load > Charge maximum moyenne de cisaillement > Durchschnittliche Querlast
D	N_{rec} [kN]	Carico ammissibile a trazione > Admissible tensile load > Charge admissible de traction > Zulässige Zuglast
E	V_{rec} [kN]	Carico ammissibile a taglio > Admissible shear load > Charge admissible de cisaillement > Zulässige Querlast
L	M_{rec} [Nm]	Momento flettente ammissibile > Admissible bending moment > Moment fléchissant conseillé > Empfohlene Biegemoment

> Carichi validi per singolo ancorante senza influenza di interasse e distanza dal bordo e $h \geq 2h_{ef}$
 > Loads for single anchor with no influence of spacing and edge distance and with $h \geq 2h_{ef}$
 > Charges valables pour chaque ancrage sans influence d'interaxe et distance du bord et $h \geq 2h_{ef}$
 > Passende Ringe für den einzelnen Veranker, ohne Achsenabstandseinfluss und des Randabstands und $h \geq 2h_{ef}$

> 1kN = 100 Kg

> Azione di taglio non diretta verso il bordo
 > Shear directed away from the edge
 > Action de cisaillement pas dirigée vers le bord
 > Queraktion nicht an den Rand gerichtet

> Coefficiente di sicurezza globale incluso
 > General safety factor included
 > Coefficient de sécurité générale inclu
 > Generelle Sicherheitskoeffizient inbegriffen

> Coefficiente lato carichi utilizzato = 1,4
 > Load increasing safety coefficient used = 1,4
 > Coefficient côté charge utilisé = 1,4
 > Verwendeter Lasterhöhungssicherheitskoeffizient = 1,4

OPTION 7

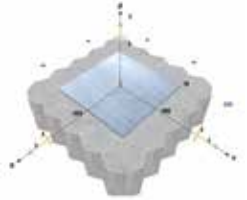
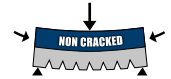

NWS-CE

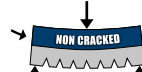
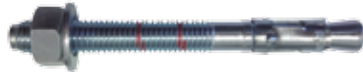

Omologato CE Opzione 7 > Approved CE Option 7
 Homologué CE Option 7 > Zulassung CE Option 7

ARTICOLO ITEM	CLASSE CALCESTRUZZO CONCRETE	CARICO ULTIMO MEDIO A TRAZIONE AVERAGE ULTIMATE TENSION LOAD	CARICO ULTIMO MEDIO A TAGLIO AVERAGE ULTIMATE SHEAR LOAD	CARICO AMMISSIBILE A TRAZIONE ADMISSIBLE TENSILE LOAD	CARICO AMMISSIBILE A TAGLIO ADMISSIBLE SHEAR LOAD	MOMENTO FLETTENTE AMMISSIBILE ADMISSIBLE BENDING MOMENT
CE	$f_{ck}/f_{ck,cube}$ [N/mm ²]	N_{Rum} [kN]	V_{Rum} [kN]	N_{rec} [kN]	V_{rec} [kN]	M_{rec} [Nm]
NWS-CE 6	C20/25	10,7	6,2	3,9	2,9	4,4
NWS-CE 8-60 *	C20/25	13,6	10,9	3,5	4,9	10,9
NWS-CE 8	C20/25	17,6	16,5	4,7	5,3	10,9
NWS-CE 10-70 *	C20/25	17,9	17,4	4,7	6,5	21,7
NWS-CE 10-80 *	C20/25	17,9	17,4	4,7	6,5	21,7
NWS-CE 10	C20/25	21,8	20,8	6,3	8,4	21,7
NWS-CE 12-90 *	C20/25	23,2	23,0	6,3	8,4	36,6
NWS-CE 12-100 *	C20/25	23,2	23,0	6,3	8,4	36,6
NWS-CE 12	C20/25	34,5	32,8	9,9	11,7	36,6
NWS-CE 14	C20/25	41,8	36,8	11,9	16,0	58,4
NWS-CE 16	C20/25	51,8	48,3	13,8	21,9	93,2
NWS-CE 20	C20/25	70,5	77,3	19,8	32,1	170,5

(*) Con affondamento ridotto > Reduced embedment depth > Profondeuse d'ancrage reduites > Anwendungen mit reduzierte Verankerungstiefen

NWS-CEX4

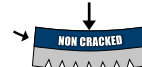
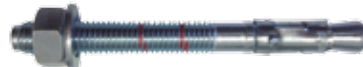

Omologato CE Opzione 7 > Approved CE Option 7
 Homologué CE Option 7 > Zulassung CE Option 7

ARTICOLO ITEM	CLASSE CALCESTRUZZO CONCRETE	CARICO ULTIMO MEDIO A TRAZIONE AVERAGE ULTIMATE TENSION LOAD	CARICO ULTIMO MEDIO A TAGLIO AVERAGE ULTIMATE SHEAR LOAD	CARICO AMMISSIBILE A TRAZIONE ADMISSIBLE TENSILE LOAD	CARICO AMMISSIBILE A TAGLIO ADMISSIBLE SHEAR LOAD	MOMENTO FLETTENTE AMMISSIBILE ADMISSIBLE BENDING MOMENT
CE	$f_{ck}/f_{ck,cube}$ [N/mm ²]	N_{Rum} [kN]	V_{Rum} [kN]	N_{rec} [kN]	V_{rec} [kN]	M_{rec} [Nm]
NWS-CEX4 6	C20/25	12,8	10,1	4,3	2,8	4,3
NWS-CEX4 8	C20/25	23,8	18,4	5,7	5,1	10,6
NWS-CEX4 10-70 *	C20/25	22,9	34,1	4,8	6,5	21,1
NWS-CEX4 10	C20/25	33,4	34,1	6,3	8,2	21,1
NWS-CEX4 12-90 *	C20/25	30,0	52,1	6,3	8,5	36,9
NWS-CEX4 12	C20/25	37,0	52,1	9,9	11,8	36,9
NWS-CEX4 16	C20/25	68,5	61,4	13,9	22,1	94,0
NWS-CEX4 20	C20/25	104,7	137,2	19,8	35,4	182,8

(*) Con affondamento ridotto > Reduced embedment depth > Profondeuse d'ancrage reduites > Anwendungen mit reduzierte Verankerungstiefen

TK (ex NW-CE)

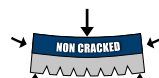

ARTICOLO ITEM	CLASSE CALCESTRUZZO CONCRETE	CARICO ULTIMO MEDIO A TRAZIONE AVERAGE ULTIMATE TENSION LOAD	CARICO ULTIMO MEDIO A TAGLIO AVERAGE ULTIMATE SHEAR LOAD	CARICO AMMISSIBILE A TRAZIONE ADMISSIBLE TENSILE LOAD	CARICO AMMISSIBILE A TAGLIO ADMISSIBLE SHEAR LOAD	MOMENTO FLETTENTE AMMISSIBILE ADMISSIBLE BENDING MOMENT
	$f_{ck}/f_{ck,cube}$ [N/mm ²]	N_{Rum} [kN]	V_{Rum} [kN]	N_{rec} [kN]	V_{rec} [kN]	M_{rec} [Nm]
TK 8	C20/25	10,0	7,9	3,6	3,8	10,7
TK 12	C20/25	21,3	12,7	5,7	4,2	37,3
TK 16	C20/25	34,6	24,5	9,9	5,4	94,8

NOTA. Dati tecnici, di installazione e di carico possono essere oggetto di revisione. Per una versione aggiornata consultare le schede tecniche sul sito www.bossong.com o contattare il nostro Ufficio Tecnico.

WARNING. Installation and loads technical data can be modified by us. For update technical data sheet see www.bossong.com or be in contact with our Technical Office.

NOTE. Données techniques, d'installation et de charge peuvent être objet de révision. Pour une version mise à jour, consulter les fiches techniques dans le site internet www.bossong.com ou contacter notre Bureau Technique.

ANMERKUNG. Technische Daten, Installationsangaben und Lastdaten können modifiziert werden. Für die aktualisierte Version sind die technischen Blätter auf der Webseite www.bossong.com nachzuschauen, oder unser Technisches Büro soll konsultiert werden.

SCHEDA TECNICA TECHNICAL DATA SHEET FICHE TECHNIQUE TECHNISCHES DATENBLATT



NWS-CE1

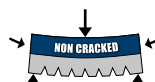

Omologato CE Opzione 1 > Approved CE Option 1
Homologué CE Option 1 > Zulassung CE Option 1

ARTICOLO ITEM	CLASSE CALCESTRUZZO CONCRETE	CARICO ULTIMO MEDIO A TRAZIONE AVERAGE ULTIMATE TENSION LOAD	CARICO ULTIMO MEDIO A TAGLIO AVERAGE ULTIMATE SHEAR LOAD	CARICO AMMISSIBILE A TRAZIONE ADMISSIBLE TENSILE LOAD	CARICO AMMISSIBILE A TAGLIO ADMISSIBLE SHEAR LOAD	MOMENTO FLETTENTE AMMISSIBILE ADMISSIBLE BENDING MOMENT
CE	$f_{ck}/f_{ck,cube}$ [N/mm ²]	N_{rum} [kN]	V_{rum} [kN]	N_{rec} [kN]	V_{rec} [kN]	M_{rec} [Nm]
NWS-CE1 8	C20/25	11,1	13,2	3,6	6,3	12,9
NWS-CE1 10	C20/25	16,3	19,6	4,8	9,3	25,6
NWS-CE1 12	C20/25	21,6	25,2	6,3	12,0	44,9
NWS-CE1 16	C20/25	43,8	45,8	13,9	21,8	114,2
NWS-CE1 20	C20/25	49,3	72,2	15,9	34,4	222,5

NW-S

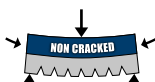

Con Dado e Rondella > With Nut and Washer
Avec Écrou et Rondelle > Mit Mutter und Scheibe

ARTICOLO ITEM	CLASSE CALCESTRUZZO CONCRETE	CARICO ULTIMO MEDIO A TRAZIONE AVERAGE ULTIMATE TENSION LOAD	CARICO ULTIMO MEDIO A TAGLIO AVERAGE ULTIMATE SHEAR LOAD	CARICO AMMISSIBILE A TRAZIONE ADMISSIBLE TENSILE LOAD	CARICO AMMISSIBILE A TAGLIO ADMISSIBLE SHEAR LOAD
N W - S	$f_{ck}/f_{ck,cube}$ [N/mm ²]	N_{rum} [kN]	V_{rum} [kN]	N_{rec} [kN]	V_{rec} [kN]
NWS 6-45	C20/25	8,4	6,2	2,8	2,9
NWS 6-60	C20/25	10,1	6,2	3,4	2,9
NWS 6 (70...180)	C20/25	10,7	6,2	3,9	2,9
NWS 8-50	C20/25	8,9	8,9	3,0	2,9
NWS 8-65	C20/25	15,8	11,0	4,2	3,5
NWS 8-75	C20/25	16,5	11,0	4,4	3,5
NWS 8 (90...155)	C20/25	17,6	16,5	4,7	5,3
NWS 10-70	C20/25	16,5	17,4	4,4	7,2
NWS 10-80	C20/25	18,5	17,4	5,0	7,2
NWS 10 (90...230)	C20/25	21,8	20,8	6,3	8,4
NWS 12-80	C20/25	18,3	25,3	5,3	9,0
NWS 12-90	C20/25	20,4	25,3	6,0	9,0
NWS 12 (100...250)	C20/25	34,5	32,8	9,9	11,7
NWS 14-80	C20/25	18,4	18,4	5,2	8,0
NWS 14-100	C20/25	20,6	29,0	5,9	12,6
NWS 14 (120...250)	C20/25	41,8	36,8	11,9	16,0
NWS 16 (90...110)	C20/25	21,7	21,7	5,8	9,8
NWS 16-125	C20/25	31,5	47,1	8,5	21,4
NWS 16 (145...280)	C20/25	51,8	48,3	13,8	21,9
NWS 20-120	C20/25	31,9	52,7	9,1	21,9
NWS 20 (170...270)	C20/25	70,5	77,3	19,8	32,1

NW-B NW-X2

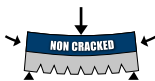

Con Dado e Rondella > With Nut and Washer
Avec Écrou et Rondelle > Mit Mutter und Scheibe

N W - B	N W - X 2	$f_{ck}/f_{ck,cube}$ [N/mm ²]	N_{rum} [kN]	V_{rum} [kN]	N_{rec} [kN]	V_{rec} [kN]
NW 6 (45...65)		C20/25	4,5	3,2	1,5	1,5
NW 8 (50...70)		C20/25	4,5	3,2	1,5	1,5
NW 8 (75...160)		C20/25	11,4	7,8	3,8	3,7
NW 10 (60...75)		C20/25	6,3	4,4	2,1	2,1
NW 10 (90...200)		C20/25	15,6	11,1	5,2	5,3
NW 12 (75...100)		C20/25	10,8	10,1	3,6	4,8
NW 12 (140...240)		C20/25	19,8	17,0	6,6	8,1
NW 14 (140...160)		C20/25	19,8	23,0	6,6	10,9
NW 16 (125...145)		C20/25	16,2	23,5	5,4	11,2
NW 16 (175...900)		C20/25	28,8	31,9	9,6	15,2
NW 20-130		C20/25	40,0	42,0	13,3	20,0
NW 20 (160...395)		C20/25	50,0	42,0	16,7	20,0
NW 24 (180...260)		C20/25	59,4	56,7	19,8	27,0